

DOWNFORCE – 2002+ OER SIDE SKIRTS

INSTALLATION AND USER'S INSTRUCTIONS

Thank you for purchasing the Original Equipment Replica (OER) side skirts from Downforce.

Before beginning any removal or installation, please take time to thoroughly read these instructions. These are the finest skirts available to the NSX market. For the first time in the NSX market, DF has replicated these skirts with factory mounting points. This manual was created with the actual install of the side skirts, additional details were added with the contribution of our customers and NSX community.

This instruction is available for download online at <http://www.downforce.biz/manual/>

- There are several WARNING sections in the installation. Always read and follow the instruction to prevent injuries, accidents, and possible damage to the vehicle.
- The side skirts might have a hole or too that is too small. This is why we listed an electric drill on the requirements section. It is better to have a hole too small than too big.
- Do not install the Side Skirts in any way other than described in the following instructions.
- If you have any questions about the use of the Side Skirts, ask Downforce about any concerns.
- Downforce and its dealers are not responsible for injuries, accidents, and damage to persons and property that arise from the use of this product.
- This product is for off road use only.

PART NAME	2002+ OER Side Skirts
PART NUMBER	DF-AAA231
VEHICLE	ACURA NSX 1991-2005

1 Requirements



This side skirt is made to replace the factory rocker panels. When removing the factory rocker panel you will need to retain the 16 plastic rocker garnish clips on the body of the car or on the side skirts. If you are in need of these clips please inquire with DF about our customer special package of 16 for \$70.00. This offer only applies to customers who have purchased this item from DF. In actuality you may get away with using only 10 clips or less.

Part Description: Clip, Rocker Garnish
Part Number: 71807-SL0-000
Retail Price: \$7.28
Quantity Needed: 16

2 Tools and Equipments



3 Side Skirt Removal

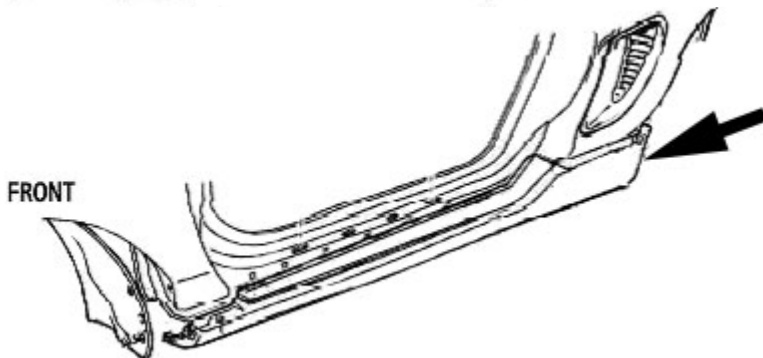
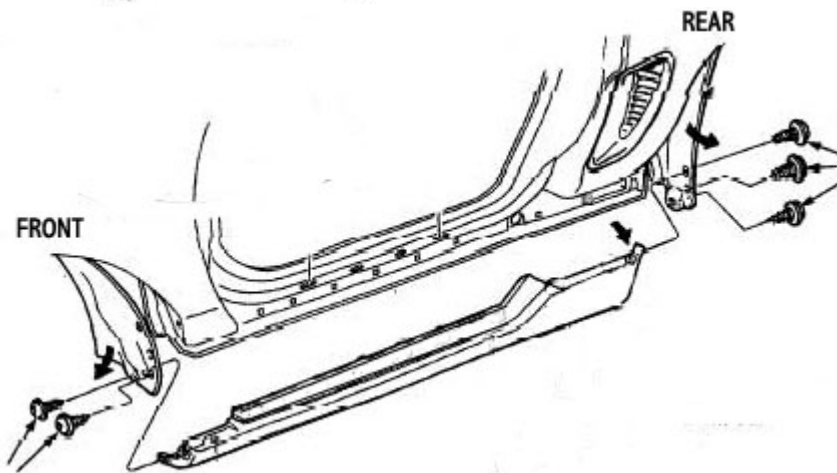
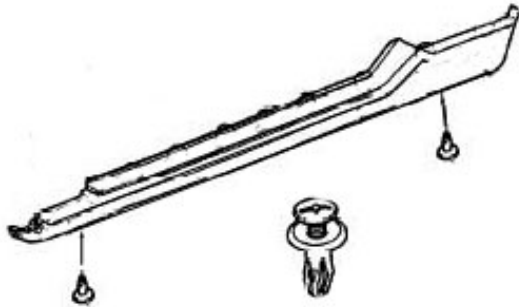

Remove the two plastic clip screws using a philips head screwdriver underneath each side skirt. Many cars are missing screws and clips because of the age of the car. You can use a generic clip as a replacement.

Remove all screws that are attached to the side skirts as shown in the picture. This is in reference to the front face and rear face of the side skirt.

Tip: You may need a special short screwdriver or a L-shaped screwdriver to get the fender liner screws out. For the front side you can turn the steering wheel to allow more clearance. The rear wheels can always be removed to provide more working room.

Remove the VIN placard from the side skirt by gently pulling them upwards. These placards are mounted on clips.

Note: Make sure not to bend the metal VIN placards!

With a rubber mallet, gently hit the rear of the side skirts and push the side skirts forward towards the front. Once the side skirts are loose you can use your hands to push the skirts out.

Warning: The side skirts will fall out once you push them out of the clips. Make sure you place a towel underneath or have someone ready to catch the skirt if you want to protect it.

4

Side Skirt Preparation

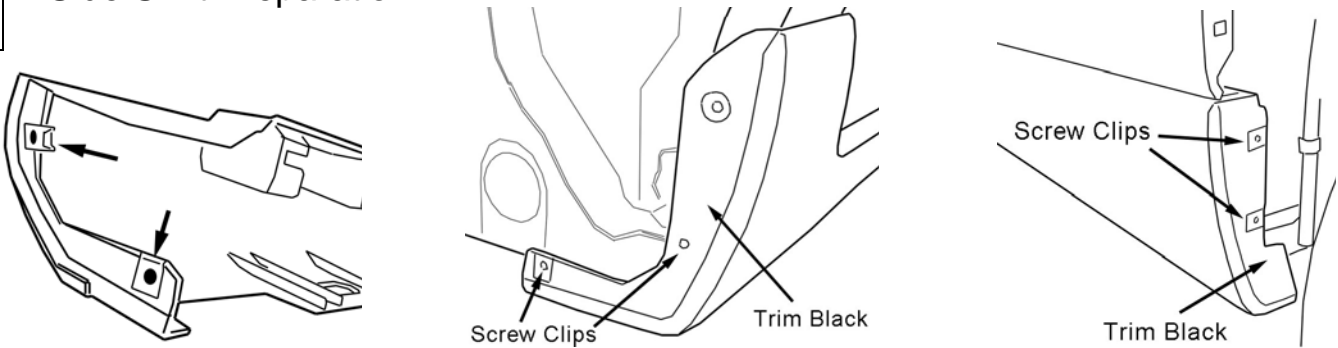

Remove the two nut screw clips from the front and two from the rear of your old side skirts. Reuse these four clips on the new skirts at the same location. These clips are used to screw down the fender liners onto the side skirts. Once they are screwed in place the side skirts will be tightly in place.

Note: OEM skirts are painted "Trim Black" on the inner part of both the front and rear edges.

5

Side Skirt Install

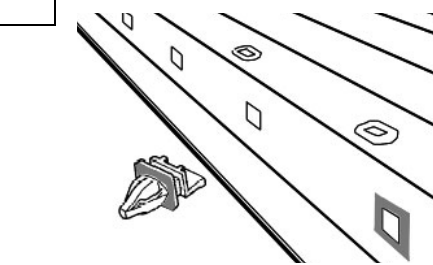

Note: The plastic garnish clips have a thin layer of foam on the backside where the clip meets the aluminum body of the car. This foam layer provides a constant tension against the garnish clips so it would not move or rattle out of place. For cars over a decade old these open cell foam layers will dry out and cracked off. We recommend using 1/16" thick foam tape to replace any missing foam. The foam can be stuck either on the body of the car surrounding the square holes or on the plastic garnish clip itself. If you are using a double sided foam tape, leave the film liner on so it will not get stuck together permanently.

DF recommends 3M Tape 4116

3M Product ID: 70-0024-8601-0

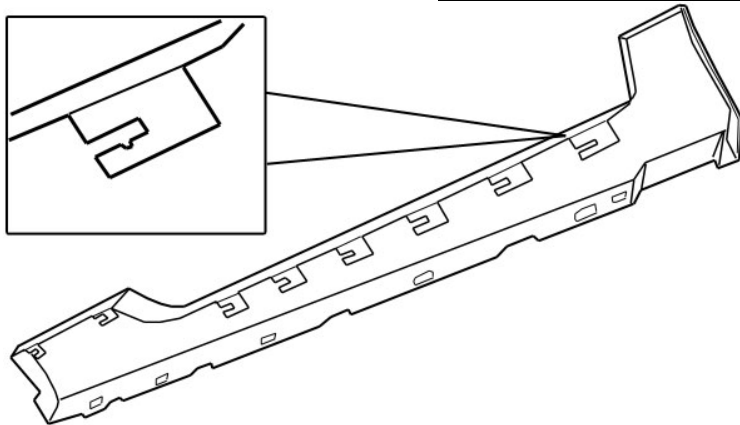
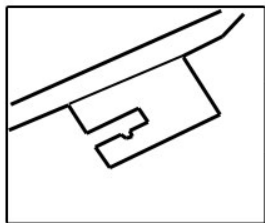

NOTICE: The orientation of the garnish clips.

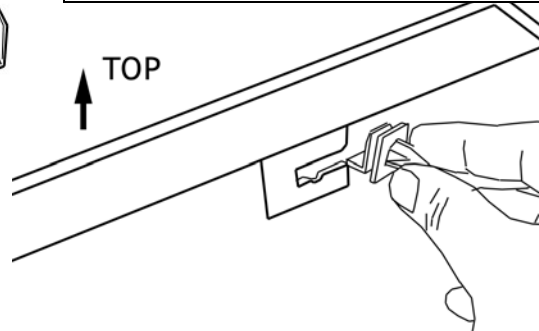

In the picture above please note this is the backside of the side skirt and the bottom of the clip has a slight dimple on the bottom side to match the factory side skirts. This dimple is used as a guide for the "plastic rocker garnish clip" placement. Slide the "Rocker Garnish Clips" onto all tabs (8 per side).

Note: Only file the tab openings if the clips will not slide on. Do not try to push the clips onto the tab with excess force. The tabs are meant to be semi-tight, this ensures that you will always have the choice of filing them down with a Dremel tool or an abrasive file. When filing the tabs, be sure to only file the topside so the dimples on the bottom will not be removed. Slowly file the opening and test fit frequently.

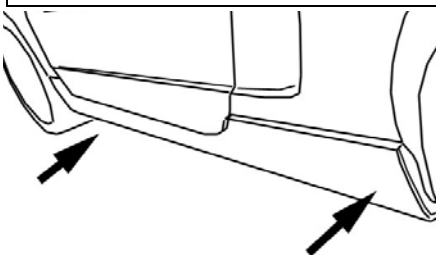

Have the door opened while you are installing the side skirts. Once all the garnish clips are installed onto the DF Skirts align the garnish clips into the square holes on the car. Once the side skirt is aligned the clips to the square holes and push the skirt in to lock the clips. To remove the skirts you will need to push them out the same way as you removed the factory skirts. Review Section 3 for the removal process.

6

Side Skirt Install

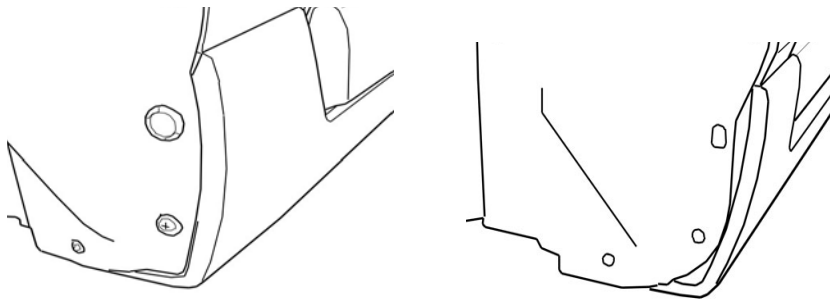

Notice: NA2 fender liners are slightly different in profile than the NA1. This difference is seen here when placing the liners over the fenders. The painter should have painted the trim black area to conceal this discrepancy. If you insist on having the new liners; you can order from the dealer or DF. DF customers can purchase the entire new OEM 2002+ fender liner set for \$240.00.

Part Number	Description	Retail
74101-SL0-030	Front Liner R	\$83.14
74151-SL0-030	Front Liner L	\$83.14
74701-SL0-010	Rear Liner R	\$83.56
74751-SL0-010	Rear Liner L	\$83.56



Qty	Part Number	Description	Retail
16	71807-SL0-000	Clip, Rocker Garnish	\$7.26

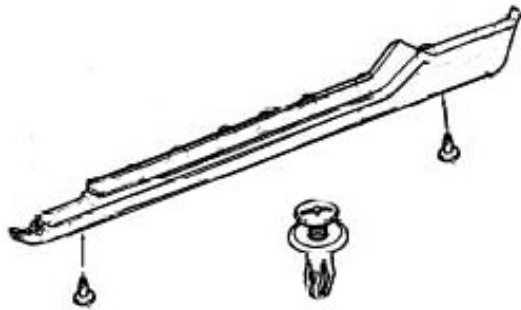

Qty	Part Number	Description	Retail
4	90505-SM4-003	Clip, Garnish	\$0.28

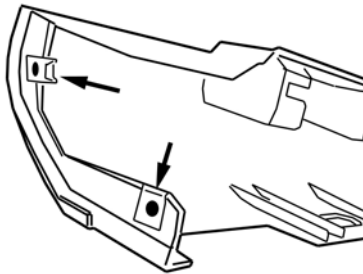

Qty	Part Number	Description	Retail
8	90331-SD5-003	Screw Clips	\$1.16